







**Fitting for top-running glass doors up to 80 kg (176 lbs.), with surface mounted running track or running track flush with the ceiling. Optionally with soft and self closing mechanism. Wall or ceiling mounting.**

**Product highlights**

-  **Aesthetics** Neutral, linear design
-  **Reliability** Very safe thanks to positive-fit glass fixing

**Technical specifications**

-  Max. 80 kg (176 lbs.)
-  Max. 4000 mm (13'1 15/32")
-  Max. 3000 mm (9'10 1/8")
-  35–80 mm (1 3/8" to 3 5/32")

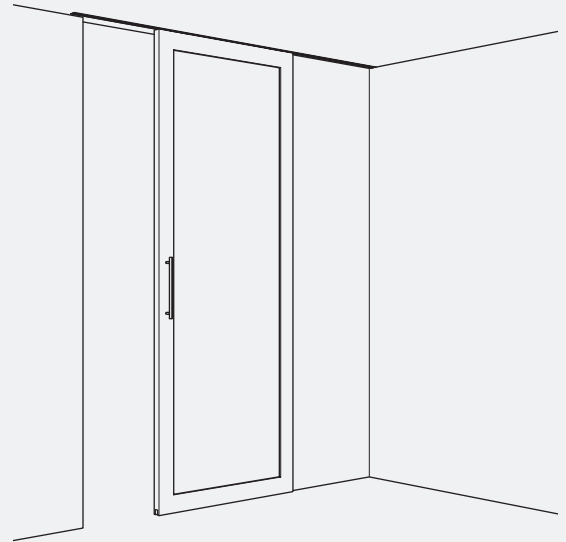

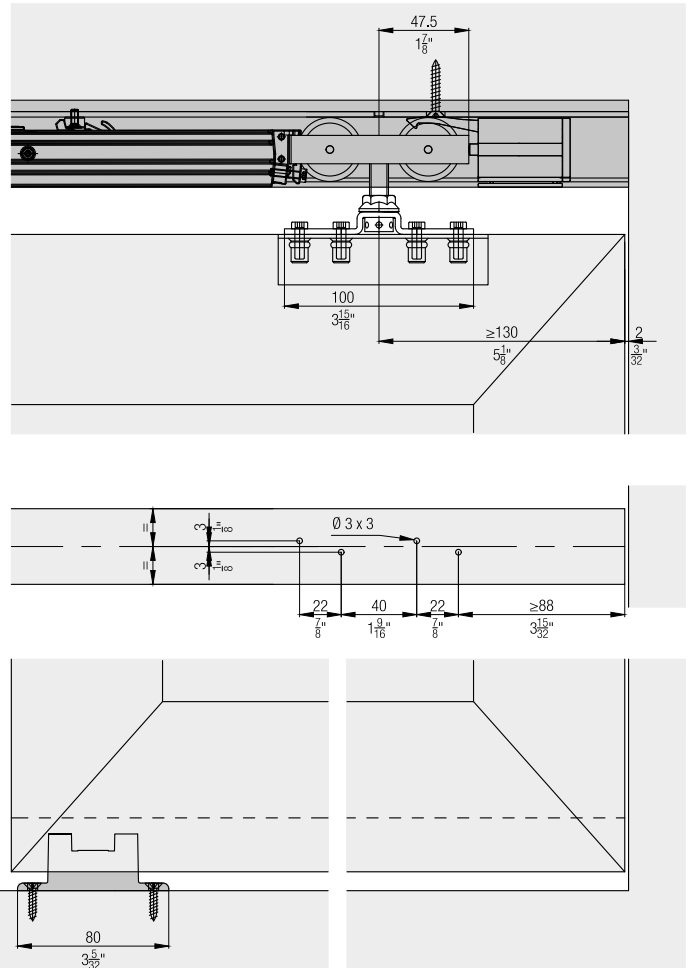
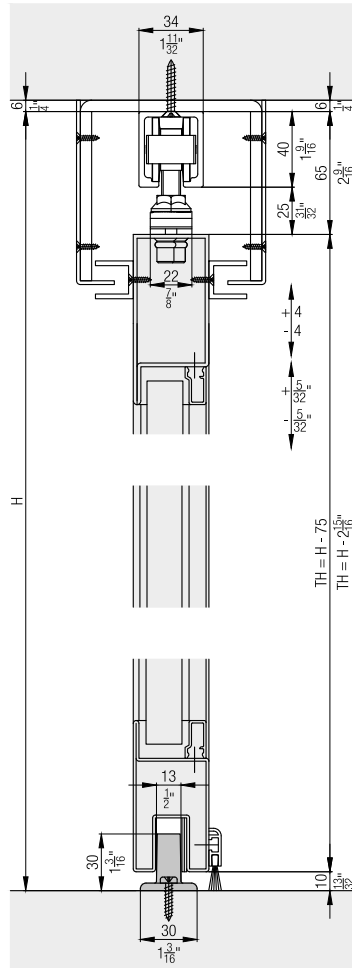

**Installation examples**



**Set for 1 glass door up to 80 kg (176 lbs.)**

	No.
Hawa Junior 80 M, for 1 door	25688

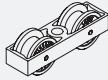
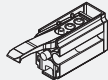
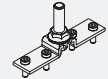
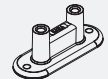
**Set consisting of:**

		25688	No.
	Running gear, 2-wheeled, M10, plastic wheels	2	10407
	Stopper Hawa Junior 80/100, with adjustable retention spring	2	30138
	Top fixing plate, with hanger bolt M10 and fixing screws	2	14487
	Floor mounted guide, plastic	1	10509
	Screw-on rubber door stop	1	10629

**Running tracks**

		mm (inch)	No.
	Running track, aluminum, anodized, pre-drilled	1,400 (4' 7 1/8 ")	10189
		1,600 (5' 3 ")	10190
		1,800 (5' 10 7/8 ")	10191
		2,000 (6' 6 3/4 ")	10192
		2,200 (7' 2 5/8 ")	10193
		2,500 (8' 2 7/16 ")	10194
		3,000 (9' 10 1/8 ")	18532
		4,000 (13' 1 15/32 ")	18533
		6,000 (19' 8 7/32 ")	10186
cut to size	10188		

**Guide tracks**

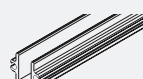

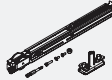

		mm (inch)	No.
	Guide track, aluminum, anodized, pre-drilled	6,000 (19' 8 7/32 ")	14414
		cut to size	14415
	Guide track, aluminum, anodized, pre-drilled	6,000 (19' 8 7/32 ")	13688
		cut to size	13690

**Soft close SoftMove 80**

**For soft closing in opening and closing direction order 2 sets.**

		No.
	Soft closing mechanism SoftMove 80	22444

**Accessories**

		No.
	Cover cap to running track, both sides, steel, chrome-plated, matt	24956
	Bottom door stopper, with centering, stainless steel look	21473
	Bottom door stopper, with centering, chrome-plated, matt	20773
	Connecting bolt for bottom guide track, 6x40 mm (1/4"x1 9/16"), steel, zinc-plated	13759

**Installation examples bottom guides**

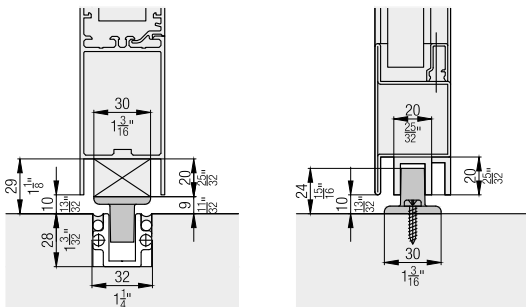

**SoftMove 80 soft closing mechanism**

Completely integrated into the running track, the SoftMove decelerates sliding doors and draws them into their final position.

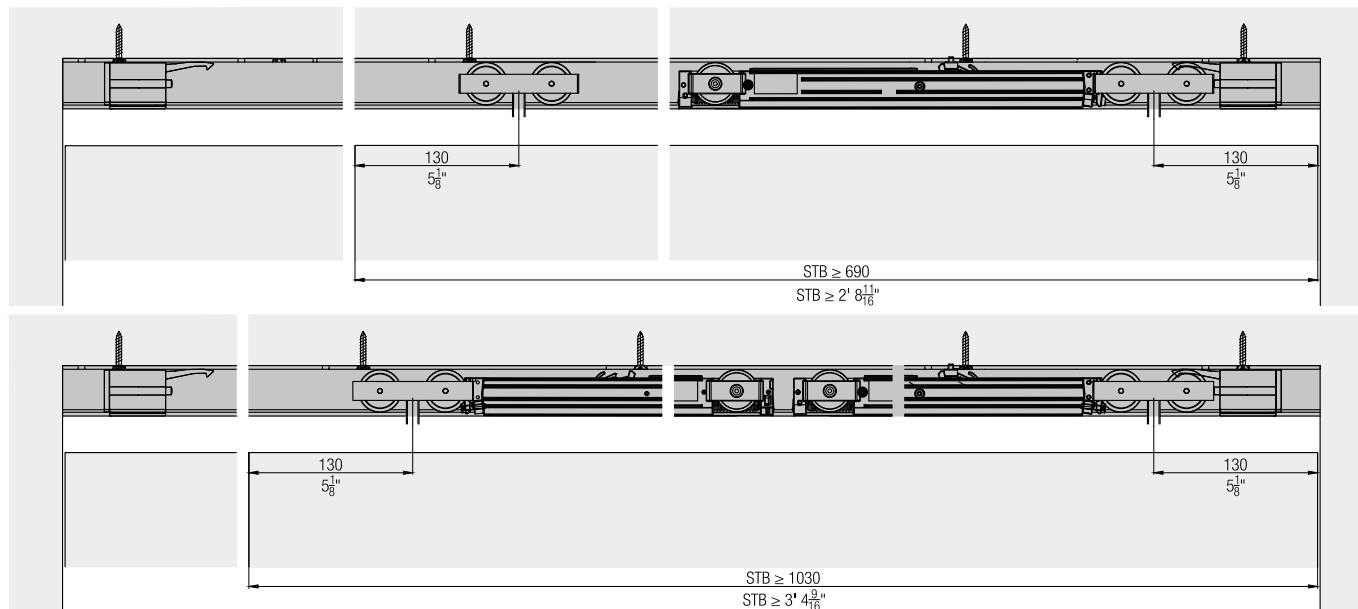

**Accessories**

- Lock solutions from page 479
- General accessories from page 487

**Planning/execution**

Further information about the product can be found on [www.hawa.com](http://www.hawa.com).